

43Z-Meter

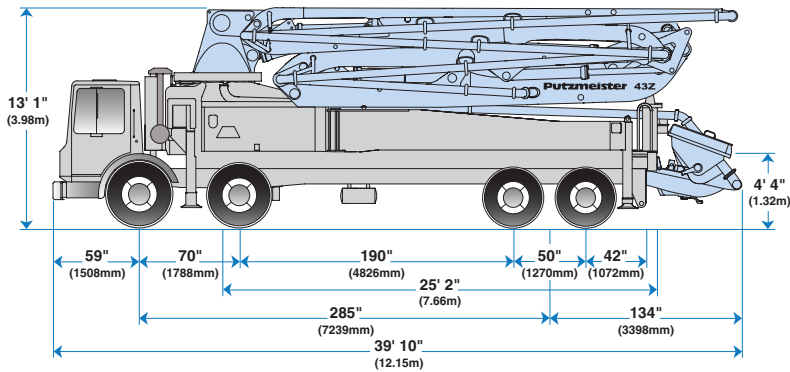

Range Diagram

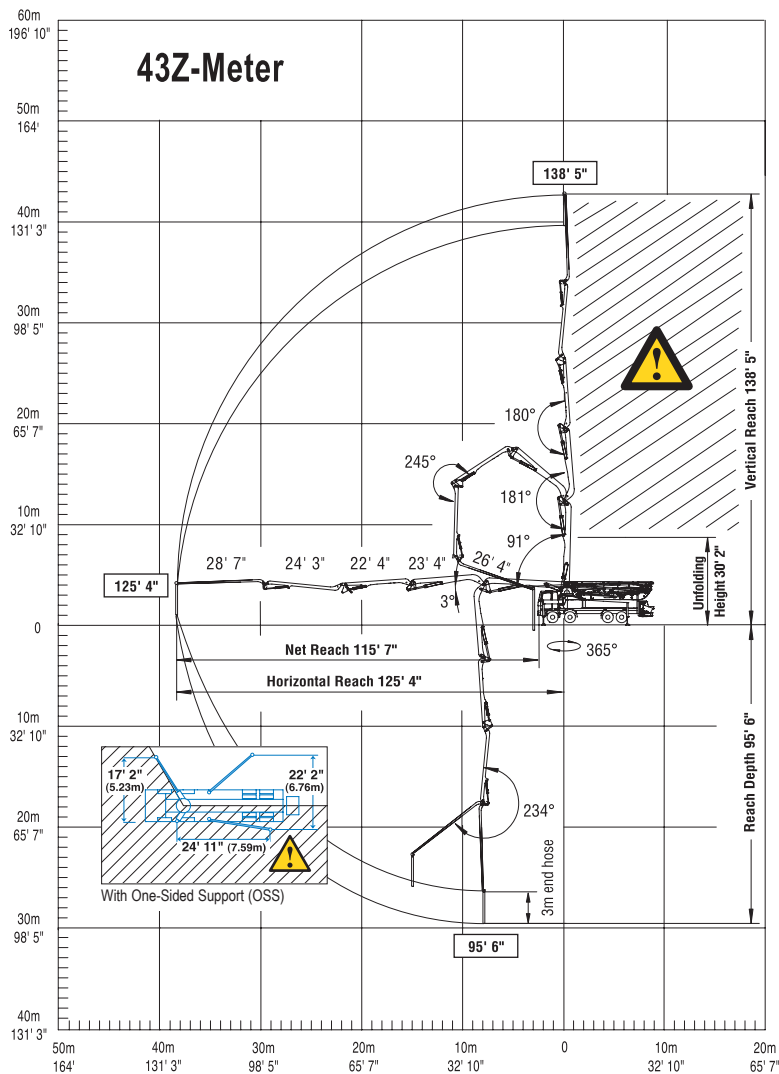

⚠ End hose not to be operated in caution area.

Photos and drawings are for illustrative purposes only. For available options, please refer to price list.

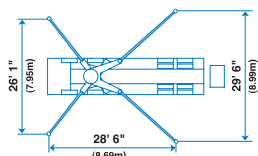

Authorized Distributor



Putzmeister America, Inc.
1733 90th Street
Sturtevant, WI 53177 USA
Telephone (262) 886-3200
(800) 884-7210
Facsimile (262) 884-6338
www.putzmeister.com



43Z-Meter Truck-Mounted Specifications

Based on Model MACK MRU 688S with .16H pump cell

Length	39' 10"	(12.15m)
Width	8' 2"	(2.50m)
Height	13' 1"	(3.98m)
Wheelbase	285"	(7,239mm)
Front axle weight	34,148 lbs	(15,489kg)
Rear axle weight	37,555 lbs	(17,035kg)
Approx. total weight	71,703 lbs	(32,524kg)

Weights are approximate and include pump, boom, truck, full hydraulic oil, driver and some fuel. Varies with options selected.

Dimensions will vary with different truck makes, models and specifications.

Boom Specifications • Z-Fold Design

Height & Reach

Vertical reach	138' 5"	(42.19m)
Horizontal reach	125' 4"	(38.20m)
Reach from front of truck*	115' 7"	(35.23m)
Reach depth	95' 6"	(29.11m)
Unfolding height	30' 2"	(9.19m)

5-Section Boom

1st section articulation	91°	
2nd section articulation	181°	
3rd section articulation	180°	
4th section articulation	245°	
5th section articulation	234°	
1st section length	26' 4"	(8.03m)
2nd section length	23' 4"	(7.11m)
3rd section length	22' 4"	(6.81m)
4th section length	24' 3"	(7.39m)
5th section length	28' 7"	(8.71m)

General Specs

Pipeline size (ID) metric ends	5"	(125mm)
Rotation	365°	
End hose — length (lightweight)	10'	(3m)
End hose — diameter	5"-4"	(125-102mm)
Outrigger spread L - R — front extend diagonally out and down	26' 1"	(7.95m)
Outrigger spread L - R — rear swing out and extend down	29' 6"	(8.99m)

Pump Specifications **43Z.16H** **43Z.20H**

Output — rod side	210 yd ³ /hr (160m ³ /hr)	—
piston side	146 yd ³ /hr (112m ³ /hr)	260 yd ³ /hr (200m ³ /hr)
Pressure — rod side	1233 psi (85 bar)	—
piston side	1885 psi (130 bar)	1233 psi (85 bar)
Material cylinder diameter	9" (230mm)	11" (280mm)
Stroke length	83" (2100mm)	83" (2100mm)
Max strokes per minute — rod side	31	—
piston side	21	26
Volume control	0-Full	0-Full
Vibrator	Standard	Standard
Hard-chromed material cylinders	Standard	Standard
Hydraulic system	Free Flow	Free Flow
Hydraulic system pressure	5075 psi (350 bar)	5075 psi (350 bar)
Differential cylinder diameter	5.5" (140mm)	5.5" (140mm)
Rod diameter	3.1" (80mm)	3.1" (80mm)
Maximum size aggregate	2.5" (63mm)	2.5" (63mm)
Water tank — pedestal	40 gal (145L)	40 gal (145L)
outrigger	153 gal (580L)	153 gal (580L)

Maximum theoretical values listed

* Applies to units mounted on PMA stock truck — MACK MRU 688S

• Standard delivery line system rated at max line pressure of 1233 psi (85 bar)